

RADIO FREQUENCY IDENTIFICATION (RFID) BASED ATTENDANCE SYSTEM WITH AUTOMATIC DOOR UNIT

Ononiwu G. Chiagozie

Department of Electrical/Electronic Engineering,
Federal University Of Technology, Owerri,
NIGERIA.

Okorafor G. Nwaji.

Department of Electrical/Electronic Engineering,
Federal University Of Technology, Owerri,
NIGERIA.

nwaji2000@yahoo.com

ABSTRACT

Radio-frequency identification (RFID) is a technology that uses radio waves to transfer data from an electronic tag, called RFID tag or label, attached to an object, through a reader for the purpose of identifying and tracking the object. RFID technology which is a matured technology that has been widely deployed by various organizations as part of their automation systems. In this study, an RFID based system has been built in order to produce a time-attendance management system. This system consists of two main parts which include: the hardware and the software. The hardware consists of the motor unit and the RFID reader. The RFID reader, which is a low-frequency reader (125 kHz), is connected to the host computer via a serial to USB converter cable. The Time-Attendance System GUI was developed using visual basic.Net. The Time-Attendance Management System provides the functionalities of the overall system such as displaying live ID tags transactions, registering ID, deleting ID, recording attendance and other minor functions. This interface was installed in the host computer.

Keywords: Radio-frequency identification, RFID technology, radio waves

INTRODUCTION

Radio-frequency identification (RFID) is a technology that uses radio waves to transfer data from an electronic tag, called RFID tag or label, attached to an object, through a reader for the purpose of identifying and tracking the object. Radio frequency identification (RFID) is a matured technology that incorporates the use of electromagnetic or electrostatic coupling in the radio frequency portion of the electromagnetic spectrum to uniquely identify an object, animal, or person. RFID chips contain a radio transmitter that emits a coded identification number when queried by a reader device. Some RFID tags can be read from several meters away and beyond the line of sight of the reader. The application of bulk reading enables an almost-parallel reading of tags. This small type is incorporated in consumer products, and even implanted in pets, for identification.

The tag's information is stored electronically. The RFID tag includes a small RF transmitter which transmits an encoded radio signal to interrogate the tag, and receiver which receives the message and responds with its identification information. Some RFID tags do not use a battery. Instead, the tag uses the radio energy transmitted by the reader as its energy source. The RFID system design includes a method of discriminating several tags that might be within the range of the RFID reader.

RFID can be used in many applications. A tag can be affixed to any object and used to track and manage inventory, assets, people, etc. For example, it can be affixed to cars, computer equipment, books, mobile phones, etc. The Healthcare industry has used RFID to reduce counting, looking for things and auditing items. Many financial institutions use RFID to track key assets and automate compliance. Also with recent advances in social media RFID is being used to tie the physical world

with the virtual world. RFID in Social Media first came to light in 2010 with Facebook's annual conference.

RFID is a superior and more efficient way of identifying objects than manual system or use of bar code systems that have been in use since the 1970s. Furthermore, passive RFID tags (those without a battery) can be read if passed within close enough proximity to an RFID reader. It is not necessary to "show" the tag to the reader device, as with a bar code. In other words it does not require line of sight to "see" an RFID tag, the tag can be read inside a case, carton, box or other container, and unlike barcodes RFID tags can be read hundreds at a time. Bar codes can only be read one at a time.

Radio frequency identification (RFID) is a matured technology that incorporates the use of electromagnetic or electrostatic coupling in the radio frequency portion of the electromagnetic spectrum to uniquely identify an object, animal, or person. They are grouped under the automatic identification (Auto-ID) technologies. RFID tags are not an "improved bar code" as the proponents of the technology would like you to believe. An RFID system consists of three components which include: an antenna, a transceiver and a transponder (the tag). The antenna and the transceiver are often incorporated into one reader. The antenna uses radio frequency waves to transmit a signal that activates the transponder. When activated, the tag transmits data back to the antenna. The RFID can read the tag using Radio Frequency, meaning that the RFID reader can be read from a distance, right through your clothes, wallet, bags etc. An RFID tag consists of unique ID for each tag. The RFID technology has been in existence since the early 1920s. This technology has been used in libraries, museums, race timing, toll collection and contactless payment, tracking of persons and animals etc.

The RFID attendance system is an automatic embedded system used in taking attendance of registered persons in a particular organization. The RFID attendance system offers an organization, the efficiency and convenience associated with RFID technology at a low cost. This method is fast as well as simple. Each employee uses an RFID card and the reader records the data when the employee enters or exits. RFID devices and software must be supported by a sophisticated software architecture that enables the collection and distribution of location based information in near real time. A complete picture of the RFID attendance system combines the RFID Tags and readers with access to global standardized database, ensuring real time access to up-to-date information on the card. The card contains a unique identification number called an electronic product code (EPC).

Nowadays, there are lots of companies around the world and some of them consist of workers up to 10 thousand or more. To handle a large number of workers may be a problem especially to get the attendance of the workers. The manual process means that whenever a worker comes to work, he goes to sign at the time officer's table. This manual process has some flaws because in a case where a worker bribes the time officer or is familiar with him, the time officer may tamper with the attendance records. This would be a big problem in the company and might affect the productivity and management of the company.

The suitable solution for this problem is by designing a system that will record attendance automatically. In this project, RFID system is used to record the numbers of employees' attendance automatically. The ID cards of the employees is embedded with RFID tag which is read by a reader. This RFID system is interfaced to a database through a computer. This method is more effective to prevent problem encountered when getting attendance manually. Below is the block diagram of an RFID attendance system.

Related Works

The use of Radio-frequency identification (RFID) technology in automated electronic environment and for tracking objects has been widely researched upon by researchers and deployed by various organizations as part of their automation systems. References [21] and [7] provide examples of a real RFID contact less data link deployments that utilize RFID technology for object tracking and automated data collection solution. RFID is a technology that uses radio waves to transfer data from

an electronic tag, called RFID tag or label, attached to an object, through a reader for the purpose of identifying and tracking the object

In 1945, Leon Theremin invented an espionage tool (for spy activities) for the Soviet Union which retransmitted incident radio waves with audio frequency information. Sound waves vibrated a diaphragm which slightly altered the shape of the resonator, which modulated the reflected radio frequency even though this device was covert listening device, not an identification device or tag, it is considered to be a predecessor of radio frequency identification (RFID) technology because it was likewise passive, being energized and activated by waves from an outside source. Similar technologies such as the IFF (identification friend and foe) transponder developed in the United Kingdom, was routinely used by the allies in the World War 2 to identify aircrafts as friend or foe. Transponders are still used by most powered aircrafts to this day.

Mario .W. Cardullo was the first to have received the United States patent for an active RFID tag with re-writable memory on January 23, 1973 [4]. In that same year, Charles Walton, a California entrepreneur, received a patent for a passive transponder used to unlock a door without a key. A card with an embedded transponder communicates a reader near a door, when the reader detects a valid identification number stored within the tag, the reader unlocks the door. Walton licensed the technology to Schalgel lock of San Francisco, a lock maker and other companies [1].

Time and attendance systems are a major part of today's human resource systems, take organization towards better human resource practice, systems and excellence. The implementation of time and attendance system has a lot of advantages for the manager. The kind of system that is implemented depends upon what the organization is trying to achieve by implementing the system. There are different types of automatic attendance systems; each type of system is suited to different needs and requirements [9]. Some of the most common types include; biometric attendance system, magnetic stripe attendance system, barcode attendance system, and RFID attendance system.

Barcode Attendance System

The barcode system is a common type of time and attendance system through which the efficiency of measuring and tracking employees' time could be increased to a great degree. With the automation through barcode technology, the errors previously made in the manual payroll or attendances are eliminated. As a result, the system provides high levels of accuracy and reliability in tracking of employee attendance. In addition, the costs associated with the installation of the system are not too much relative to the cost of payroll or attendance errors.

The implementation of the barcode system is easy. Every employee is issued a badge/card in which there is a barcode. In order to check into or out of the company, the badge/card is swapped on the time clock, and the data is captured by the clock. This data from the clock can be downloaded by the manager or the administrator and then used for updating and maintaining time and attendance records.

The Universal Product Code (UPC) is a unique 12-digit number assigned to retail merchandise that identifies a product and the vendor. The Universal Product Code (UPC) on a product typically appears adjacent to its barcode, the machine-readable representation of the Universal Product Code (UPC). The UPC for a particular product is always the same. The first six digits is the vendor unique identification number. All the products that the vendor sells will have the same first six digits in their UPCs. The next five digits identify the product. The last digit is called the check digit. This is used to verify that the UPC for that specific product is correct.

Each time that UPC is read, typically by a scanner reading the barcode, a calculation is done. And, if the check digit is different compared from the one that is calculated, then the computer knows that there is something wrong with the UPC. Figure 1 is a pictorial diagram of a barcode with its universal product code (UPC) [11].

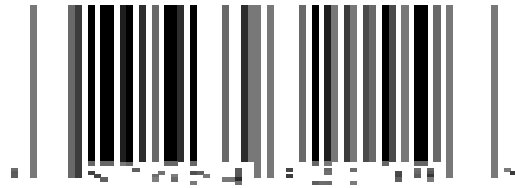

Fig.1 picture of a barcode

Biometric Attendance System

This is the study of measurable biological characteristics. In computer security, biometrics refers to authentication techniques that rely on measurable physical characteristics that can be automatically checked. There are several types of biometric identification schemes which include:-face fingerprints, retina, hand geometry, vein, voice etc. The computer uses any of these biometric identification schemes to determine who you are, and based your identity authorize your different levels of access [12]. Under this system, there is time and attendance software that is paired with a time clock for employees which uses biometric technology for authentication purposes. When these systems are in use, the employees can use their finger prints for clocking in and clocking out. This method has the great benefit that the entire process is easy as well as quick. Other advantages include elimination of the cost previously incurred in getting the employees cards. In the other systems that uses card (magnetic stripe and barcode systems), there is an ongoing expense associated with the damage, misplacement and stealing of cards and the continuous need for their restoration and maintenance.

Magnetic Stripe Attendance System

In the magnetic stripe attendance system, data is encoded in the magnetic stripe of the employee card. When the card, is swiped through the employee time clock, the information in the card's magnetic stripe is recorded by the time clock. This system also reads one card at a time and also requires contact with the reader. Figure 2 is a pictorial diagram of a card embedded with magnetic strip.

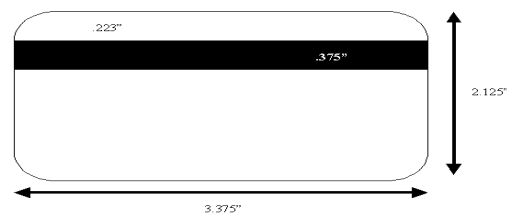

Fig.2 picture of a magnetic stripe card

Radio Frequency Identification (RFID)

A radio-frequency identification system comprises hardware shown in figure 3a & 3b, known as *interrogators* or *readers* and *tags*, also known as *labels*, as well as RFID software or RFID middleware. RFID tags are of two major types, which include Active Tag and Passive Tag.



Fig.3a RFID tag



Fig.3b RFID card and reader

RFID tags can be either passive, active or battery assisted passive. Passive RFID does not use a battery, while an active has an on-board battery that always broadcasts or beacons its signal. A battery assisted passive has a small battery on board that is activated when in the presence of a RFID reader. Most RFID tags contain at least two parts: one is an integrated circuit for storing and processing information, modulating and demodulating a radio-frequency (RF) signal, and other specialized functions; the other is an antenna for receiving and transmitting the signal.

Depending on mobility, RFID readers are classified into two different types: fixed RFID and mobile RFID. If the reader reads tags in a stationary position, it is called fixed RFID. These fixed readers are set up specific interrogation zones and create a "bubble" of RF energy that can be tightly controlled if the physics is well engineered. This allows a very definitive reading area for when tags go in and out of the interrogation zone. On the other hand, if the reader is mobile when the reader reads tags, it is called mobile RFID.

An Electrical Engineering student of the University of Malaysia; Mohd Firdaus Bin Mahyidin designed RFID technology students' attendance system 2008 [10], which only takes attendance of students and stores the information in the database. The block diagram of his project is shown figure 4. However, this system does not the incorporate a door unit which allows access to only registered users.

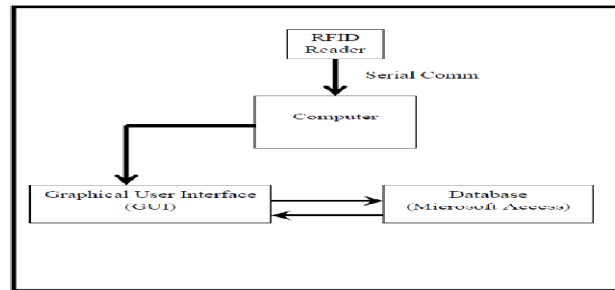

Fig.4: RFID Technology Students attendance system.

Comparing Barcode with RFID is done on table 1.

Table 1: comparisons between Barcode and RFID

	Barcode	RFID
1	Rely on the user to make contact to the reader, hence cannot be read from a distance	Do not require contact with reader, hence can be read from a distance.
2	In Barcode, only one card read at a time is allowed.	Multiple read at a time is permitted
3	Embedded information cannot be updated, hence the restriction of the repeated over-writing if the embedded election information for each card	Embedded information can be updated; this allows the repeated over-writing if embedded electronic information for each card.
4	It does not allow for the increase technologies like surveillance cameras to be activated with an employee being in the vicinity.	RFID has increased technologies like surveillance cameras to be activated in conjunction with an employee being in their vicinity.
5	It is slower and requires time of sight to function.	RFID is faster and does not require line of sight.
6	It has lower data storage transponder.	It has higher data storage.
7	This transponder is bogus, and cannot be incorporated in small items.	The transponder is miniaturized, and can be incorporate in other items. For example in 2009 researchers successfully glued RFID micro-transponder to live ants [1]

Radio Frequency Identification (RFID) Attendance System

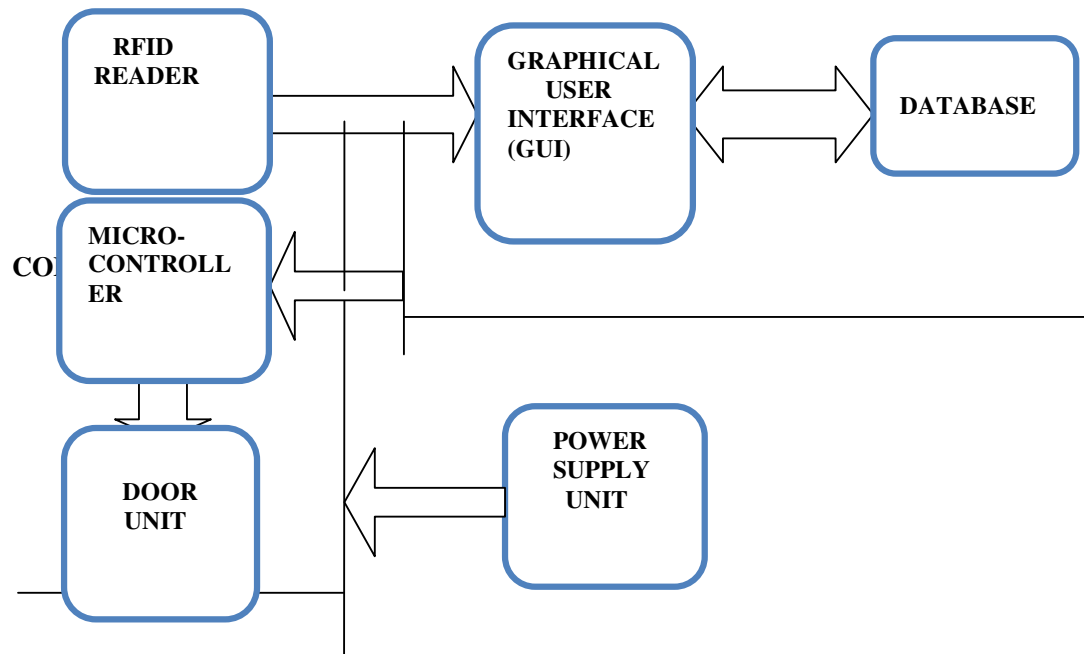

Fig.5 Block diagram of an RFID attendance system with door unit

The RFID attendance system offers the organization, the efficiency and convenience associated with RFID technology at a low cost. Each employee uses an RFID card and the reader records the data when the employee enters or exits.

Operations

RFID devices and software are supported by a sophisticated software architecture that enables the collection and distribution of location based information in near real time. A complete picture of the RFID attendance system combines the RFID Tags and readers with access to global standardized database, ensuring real time access to up-to-date information on the card. The card contains a unique identification number called an electronic product code (EPC). The RFID tag can be read from a distance and the embedded electronic information for each card can be over written repeatedly. This increases technologies like surveillance cameras to be activated in conjunction with an employee being in their vicinity. The RFID attendance system is faster, and does not require line of sight. The RFID system has higher data storage. In the RFID systems, the transponders are also easy to conceal or incorporate in other items. For example in 2009, researchers successfully glued RFID micro transponder to live ants in order to study their behavior [1]. Furthermore, multiple RFID cards can be read all at the same time. Information about the employees' access and attendance can be stored on the database.

RFID Frequency band

Frequency refers to the size of the radio waves used to communicate between the RFID system's components. It can be assumed that higher frequency resulting faster data transfer rate and longer reading distance. However as frequency increases, the sensitivity to environmental factor also increases. RFID system currently operates at Low Frequency, High Frequency and Ultra High Frequency. Generally a lower frequency means a lower read range and slower data read rate, but increased capabilities for reading near or on metal or liquid surfaces. The frequency chart is shown in table 2 [18].

Table 2: RFID Frequency Table

Frequency band	Description	Operating range	Application	benefits	Drawbacks
125KHz to 134KHz	Low frequency	Less than 0.5m to 1.5ft	Access control, animal tracking point of sale application, product authentication, vehicle immobilizer etc	Works well around water and metal products	Short read range and slower read rate
13.56M Hz	High frequency	Less than 1m to 3ft	Smartcards library books, airline baggage etc	Low cost of tag	High read rate when compared to low frequency
860MHz To 930MHz	Ultra high frequency (UHF)	3m to 9ft	Parking lot access, electronic toll collection etc	EPC standard built around this frequency	Does not work well with high water or metal content
2.4GHz	microwave	1m to 3ft	Airline baggage, electronic toll collection	Most expensive	Fastest read rate

Miniaturization

RFIDs are easy to conceal or incorporate in other items. For example, in 2009 researchers at Bristol University successfully glued RFID micro-transponders to live ants in order to study their behavior [6]. This trend towards increasingly miniaturized RFIDs is likely to continue as technology advances. Hitachi holds the record for the smallest RFID chip, at 0.05mm x 0.05mm. This is 1/64th the size of the previous record holder, the mu-chips. Manufacture is enabled by using the silicon-on-insulator (SOI) process. These dust-sized chips can store 38-digit numbers using 128-bits read only memory (ROM) [7]. A major challenge is the attachment of the antennas, thus limiting read range to only millimeters.

The Radio Frequency Identification (RFID) Application Areas

In 2010 three key factors drove a significant increase in RFID usage. They include; decreased cost of equipment and tags, increased performance to a reliability of 99.9% and a stable international standard around UHF passive tag. The areas of significant use are financial services for Information Technology asset tracking and healthcare with more than 60% of the top medical device companies using passive UHF RFID in 2010. RFID is becoming increasingly prevalent as the price of the technology decreases [7]. Therefore, the current uses include:

Electronic Vehicle Registration

With security of cars being a major concern in many countries, RFID technology is being leveraged by government for Vehicle Registration [21] [13]. This helps detect stolen cars and in their retrieval [14] [18].

Payment by Mobile Phones

Since summer 2009, two credit card companies have been working with Dallas, Texas-based Device Fidelity to develop specialized microSD cards. When inserted into a mobile phone, the microSD card can be both a passive tag and an RFID reader [19]. After inserting the microSD, a user's phone can be linked to bank accounts and used in mobile payment. Diaryqueen in conjunction with Vivotech has

also begun using RFIDs on mobile phones as part of their new loyalty and rewards program. Patrons can ask to receive an RFID tag to place on their phone. After activation, the phone can receive promotions and coupons, which can be read by Vivotech's devices [16]. Similarly, Nokia's 2008 device, the 6212, also has RFID capabilities. Credit card information can be stored, and bank accounts can be directly accessed using the enabled handset. The phone, if used as a vector for mobile payment, has added security in that users would be required to enter a passcode or PIN before payment is authorized [16].

Transportation Payments

Governments use RFID applications for traffic management, while automotive companies use various RFID tracking solutions for product management.

Car-Sharing

The Zipcar car-sharing service uses RFID cards for locking and unlocking cars and for member identification [20].

Toll Roads

The tags, which are usually the active type, are read remotely as vehicles pass through the booths, and tag information is used to debit the toll amount from a prepaid account. The system helps to speed traffic through toll plazas as it records the date, time, and billing data for the RFID vehicle tag. This has been introduced in some places in Nigeria.

Public Transit (bus, rail, subway)

In South Korea, t-money cards can be used to pay for public transit. It can also be used in most convenience stores and vending machines in subways as cash. 90% of cabs in Seoul accept card payment, including most major credit cards and the T-money card. T-money replaced UPASS, first introduced for transport payments in 1996 using MIFARE technology [15]. Also, in Hong Kong, mass transit is paid for almost exclusively through the use of an RFID technology, called the octopus card. This has also been used in various other countries like Canada, Russia etc [15].

Asset Management and Retail Sales

RFID combined with mobile computing and Web technologies provide a way for organizations to identify and manage their assets. It was initially introduced to major retail by Craig Patterson, Knoxville, TN. Mobile computers, with integrated RFID readers, can now deliver a complete set of tools that eliminate paperwork, give proof of identification and attendance.

Web based management tools allow organizations to monitor their assets and make management decisions from anywhere in the world. Web based applications now mean that third parties, such as manufacturers and contractors can be granted access to update asset data, including for example, inspection history and transfer documentation online ensuring that the end user always has accurate, real-time data. Organizations are already using RFID tags combined with a mobile asset management solution to record and monitor the location of their assets, their current status, and whether they have been maintained.

RFID is being adopted for item-level retail uses. Aside from efficiency and product availability gains, the system offers a superior form of electronic article surveillance (EAS) and a superior self checkout process for consumers. The financial services technology consortium (FSTC) set a technical standard for tagging Information Technology assets [21] and other industries have used that standard as a guideline. For instance the US State Department is now tagging IT assets with passive RFID using ISO/IEC 18000-6 standard [8].

Schools and Universities

School authorities in the Japanese city of Osaka are now chipping children's clothing, back packs, and student IDs in a primary school. Similarly, Whitcliffe Mount School in cleckheaton England uses RFID to track pupils and staff in and out of the building via a specially designed card. In the Philippines, some schools already use RFID in IDs for borrowing books and also gates in those particular schools have RFID ID scanners for buying items at a school shop and canteen, library and also to sign in and sign out for student and teacher's attendance [8].

Human Implants

Implantable RFID chips designed for animal tagging are now being used in human beings. An early experiment with RFID implants was conducted by British professor of cybernetics Kevin Warwick, who implanted a chip in his arm in 1998. In 2004 Conrad chase offered implanted chips in his night clubs in Barcelona and Rotterdam to identify their VIP customers, who in turn use it to pay for drinks. In 2004, the Mexican Attorney General's office implanted 18 of its staff members with the verichip to control access to a secure data room [15].



Fig.6a Hand with the planned location of the RFID chip

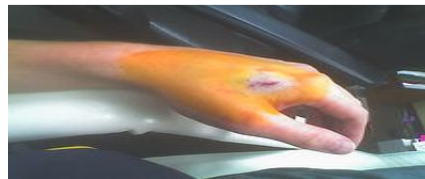

Fig.6b The hand just after the operation to insert the RFID tag was completed. The yellow is from the iodine disinfection before inserting the chip

APPLICATIONS OF RFID TECHNOLOGY IN NIGERIA

The RFID technology has been suggested to be applied in various sectors in Nigeria to reduce corruption. These sectors include; the monitoring of crude oil, tracking the movement of money, drug agencies and monitoring containers entering the country. Other proposed applications include: the cloning of documents such as certificate of occupancy, bills of lading and university certificates etc.

An RFID technology company in Nigeria started providing anti-money laundering (AML) solutions to banks. The technology tracks the movement of money and alerts the Nigerian Financial Intelligence Unit of any suspicious activities. The company is providing the service to five major Nigerian banks. This technology has been used by NAFDAC to reduce the importation and distribution of counterfeit drugs 2008 [17].

SYSTEM DESIGN AND IMPEMETATION METHODOLOGY

The method/approach used in achieving this project design include; the designing of a hardware unit consisting of a motor interfaced with a designed database and graphical user interface(GUI) that will be responsible for taking and storing the data received from the reader. And the software development

unit consisting the Microsoft visual studio, Microsoft .Net framework and Microsoft access. This is done by comparing the information received from the RFID reader to the information stored in the database.

The Hardware

The hardware architecture consists of the UME4100 RFID tag, the SEED 125 KHz RFID reader, the ATMEL AT89S52 microcontroller, the computer, the door unit, the power supply unit, the universal serial bus (USB), USB to serial converter, the RS-232 interface, the universal asynchronous receiver transmitter (UART) and the serial data transmission.

The RFID reader in figure 7 uses low frequency band, and practically, the reading distance between the tag and the reader is about 7cm. The output of this reader is transmitted serially, and data is transmitted at 9600 baud rates. However, this reader has been chosen because it has a DB9 female header, which can be used to connect to the serial port of personal computer, and it can display the unique ID of the tag in Window operating system. Its applications includes Pet Toys and Access Control System



Fig.7 The SEED RFID reader [2] (module and antenna)

The figure 8 shows the RFID tags used in this paper. These RFID tags are passive tags thus it has no internal power supply. These tags activated by radio frequency transmitted by the reader. The reading distance is about 7 cm. When the RFID reader receives the data from the tag, the data then will be compared with the data in the database to identify the holder of the tag.



Fig.8 The UEM4100 RFID tag

This design consists of the RS-232 circuit, the motor circuit and the microcontroller. The RFID reader sends signals to the RS-232 circuit which interfaces with the serial port. The microcontroller is programmed to receive signals from the RS-232 circuit and sends signals to control the motor circuit which controls the direction of movement of the door. The crystal oscillator generates pulses that enable the microcontroller to execute instructions. The microcontroller codes are written with assembly language.

The motor unit controls the movement of the door. The microcontroller sends signals to the transistor which acts as a switching device. These transistors allow current flow into the relay.

The RS-232 converts the transistor-transistor logic data to enables communication with the serial port.

The Software

The software development unit consisting: the Microsoft visual studio, Microsoft .Net framework and Microsoft access [3].

Microsoft Access Database: There are two databases designed using Microsoft Access 2007. The databases named “regDB” and “attendance”. The “regDB” database stores information of registered users. This information is used by the administration to identify and manipulating attendance information. In the other hand, the “attendance” database stores all attendance related data. Besides that, there are three tables inside the “attendance” database which act as temporary data storage which are “tagid”, “username” and “datereg”. These tables are essential to the program flow. The database has a login password which allows access. Figures 9a & 9b are the pictures of the “regDB” database and “attendance” database.

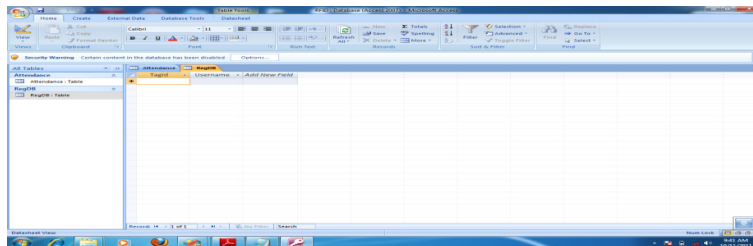

Fig..9a “regDB” database

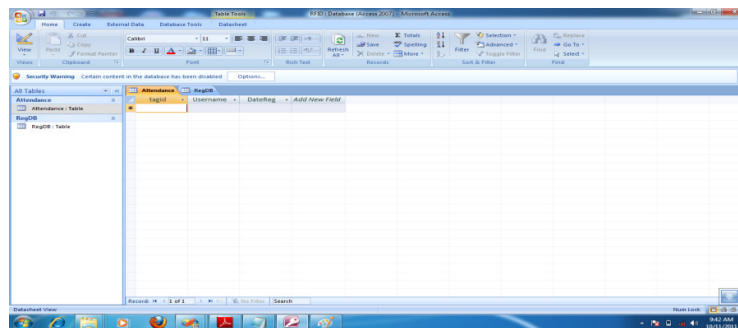
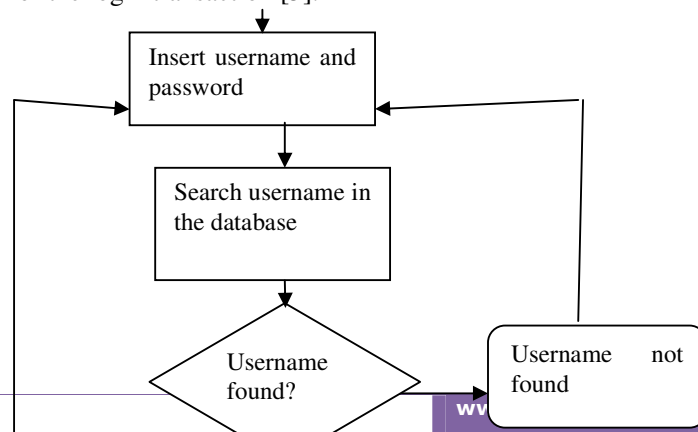

Fig.9b “Attendance” database

Time Attendance GUI Design

The GUI of the Time Attendance is developed using Microsoft Visual Studio 2008. However, it is difficult to design an attractive GUI using the basic controls provided by the Microsoft Visual Studio. Thus, third party add-on software which is Developer Express 2011 has been used to enhance the appearance of the GUI. This software is integrated into Microsoft Visual Studio 2010. The Time Attendance interface is divided into two parts which are login part and the main interface part. The purpose of the login part is to make the system more secure as user has to login before having the access of the main interface. The folder of the design project is named “RFID BASED ATTENDANCE SYSTEM”. The output of the compilation is in “Debug” folder within the project folder. Figure 10 is the flow chart for the login transaction [5].



NO

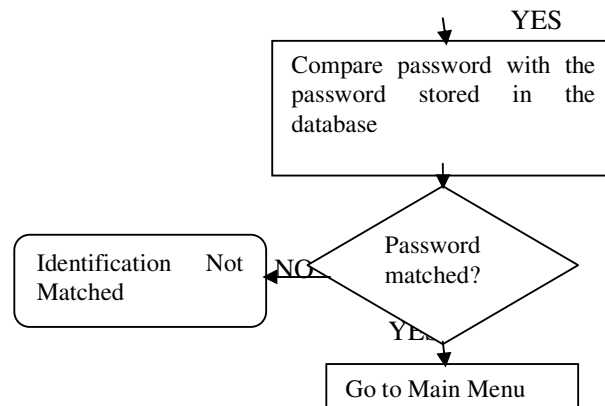

Fig. 10 Flow chart of the login transaction

CODING TECHNIQUE

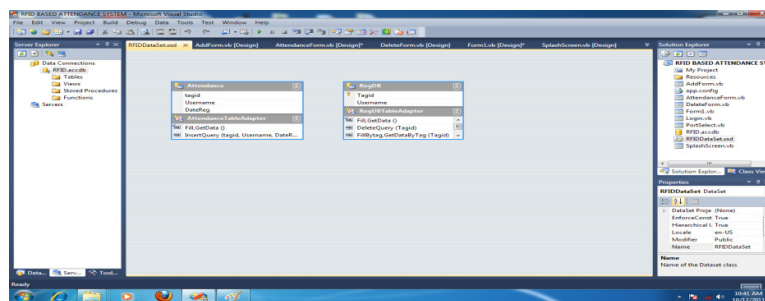

Fig.11 The dataset

Database Queries

SQL statements such as *INSERT*, *DELETE* and *UPDATE* are used to retrieve and manipulate data in the database. Besides that, getting data row from dataset method is also used to retrieve the data without manipulating it, as used to display the data in the database interface. Furthermore, *try-catch* statement is implemented to control the program exception during the queries.

Serial Port Interfacing

Microsoft Visual Studio provides the serial port class library to make communication between serial port and the window form. This method is interrupt-driven. The serial handler codes are illustrated below.

```

Private Sub SerialPort1_DataReceived(ByVal sender As Object, ByVal e As System.IO.Ports.SerialDataReceivedEventArgs) Handles SerialPort1.DataReceived

```

```

    Control.CheckForIllegalCrossThreadCalls = False

```

```

    SerialPort1.Read(MyData, 0, 14)

```

```

    For Each check As Integer In MyData

```

```

TxtRfid.AppendText(check)

Next

data = TxtRfid.Text

RegAttendance()

System.Threading.Thread.Sleep(2000)

TxtRfid.Text = ""

TxtName.Text = ""

TxtTime.Text = ""

End Sub
    
```

TESTS, RESULTS AND DISCUSSION

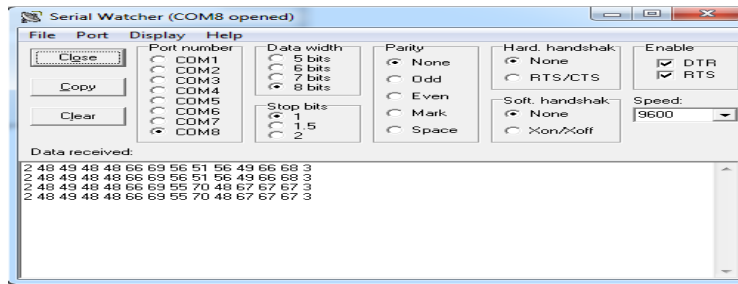

Fig.12 The RFID output

The serial watcher is used to monitor the output of the RFID tags. The computer receives 14 digits through the serial port where the first digit is the start bit, the next 10 digits is the tag code, the next 2 digits after the tag code is the checksum bit and the last digit, the end bit.

5.1.2 The Motor Unit Test

The microcontroller was tested to make sure it sends the required signal needed to operate the door. The microcontroller code was adjusted until this problem was solved, and it sends the required signals needed for the operation of the door.

Table 3 showing tests comparison of the RFID attendance with another randomly picked attendance system.

Table 3. Test comparison table between RFID and magnetic strip

TESTS	RFID	MAGNETIC STRIPE
Speed of registration	2-4 seconds	4-8seconds
Card access modes	From a distant range	By insertion in slot
Tests accuracy	1/10	2/10

Also, a stained card test was carried out with a stained both magnetic strip card and an RFID card with dirt, and then inserted the magnetic strip into the slot. The magnetic strip seemed not to work as a result of the dirt making the reader malfunction. In the case of the RFID card, the signal from the transponder was retrieved because communication is by contactless radio frequency.

OPERATION

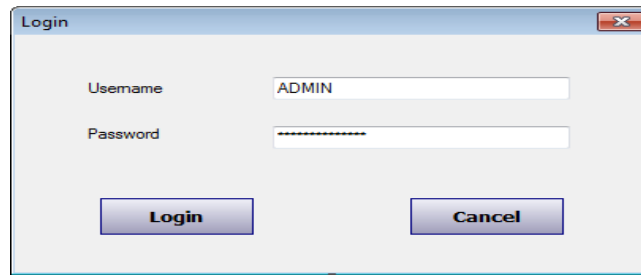

Fig.13 Login Interface

The figure13 shows the login form to get the access of the Time Attendance system by the administrator. The Administrator has no data manipulation restriction. This interface is created to limit access to only the administrator for security purposes.

The Attendance Main Interface

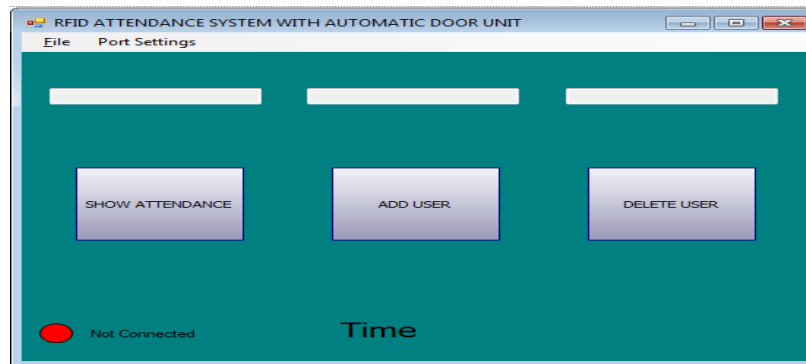

Fig.14 The attendance main interface

The figure 14 shows the attendance main interface of the system. There are three options which are “show attendance”, “add user” and “delete user”. Time attendance menu is chosen to access the time attendance system. The “show attendance” displays all the attendees’ cards that have been scanned.

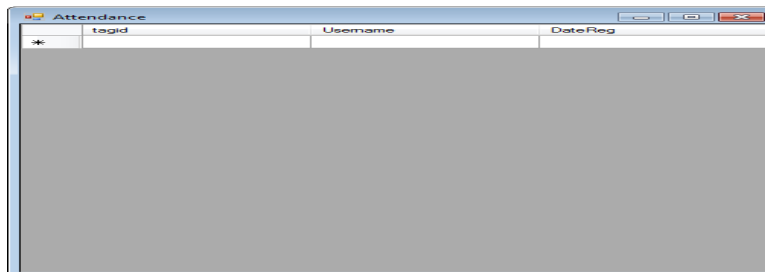

Fig.15a the show attendance interface

The “add user” is used to register a card. The card is first scanned and a username is attached to the data received before storing it in the database.

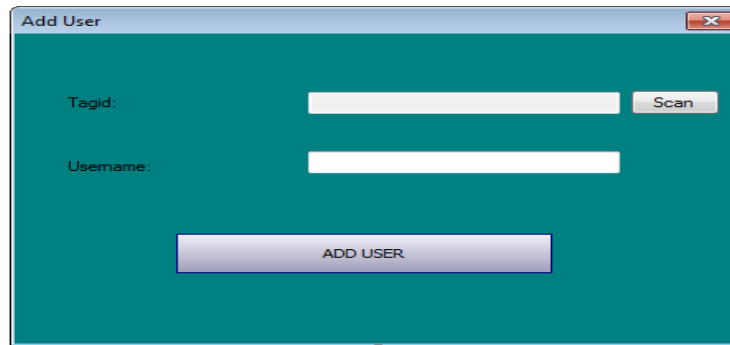

Fig.15b Add user interface

The delete user is used to remove an already registered card from the database. This is done by scanning the card and attaching the required username of the card before clicking on the delete button.

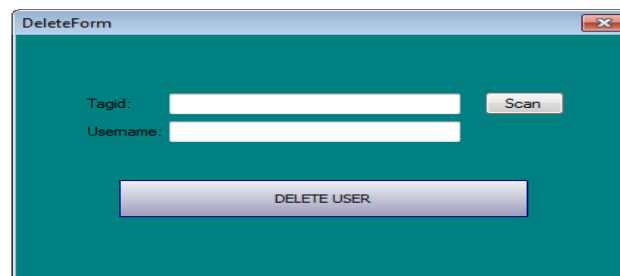

Fig. 15c Delete user interface

CONCLUSION

In conclusion, the objective to build an RFID based attendance system with a door unit was successfully achieved. In terms of performance and efficiency, this project has provided a convenient method of attendance marking compared to the traditional method of attendance system. By using databases, the data is more organized. This system is also a user friendly system as data manipulation and retrieval can be done via the interface, making it a universal attendance system. Thus, it can be implemented in either an academic institution or in organizations.

However, some further improvements can be made on this RFID in order to increase its reliability and effectiveness. *By incorporated an indicator or an LCD screen in the system to indicate when an unregistered card is scanned. *An IP camera can be integrated into this system to enable the monitor to view the person who makes the transaction to avoid a problem of a person scanning in for another person. *A reminder alert also can be developed to effectively track any ID that has been absent for an unacceptable times in a row. *Finally, this attendance system can be improved by adding a feature where the attendance system indicates when an employee or a student is late for work or classes as the case maybe.

REFERENCES

1. Daniel M. Dobkin and Steven M. Weigand (2010). *Environmental effects on RFID tag antennas*. California: Bulis Press
2. Julia Case and Anita .C. Millspaugh (2005). *Programming in visual basic NET*. Sao Paulo: Mcgraw Press

3. [Financial Consortium Publishes RFID Standards for IT Assets](#). Retrieved on 2010
4. Amirjan Bin Nawabjan (2009). *Automated attendance management software*. University of Technology, Malaysia: Degree Thesis
5. Stevan Preradovic and Nemai C. Karmakar (2006). *RFID reader: a review*. Monash University, Australia
6. Carlos .C. Murphy (2005). *Automated attendance systems*. Argentina: Javier Press
7. Mohd Firdaus Bin Mahyidin (2008). Students' attendance system using RFID technology. Malaysia.
8. Billard .F.Cookes (2001). *Fundamentals on barcode technology*. Cyprus: Rafot Press Lilimited
9. Gordon .N. Withtaker (2002). *Introduction to biometrics technology*. Dint and sons Limited
10. Markus Hansen and Sebastian Meissner (2000). *Identification and Tracking of Individuals and Social Networks using the Electronic Product Code on RFID Tag s*. Sweden: IFIP Summers Limited
11. Greene.C. Thomas (2004). *Feds approve human RFID implants*. http://www.theregister.co.uk/2004/10/14/human_rfid_implants
12. Mary Catherine O'Connor (2009). *Sun Microsystems Piloting RFID Tagging for Financial Customers*. USA: Preston Press
13. Emenike .U. Ugwuatu (2007). *Future of RFID technology in Nigeria*. Ibadan: Loyato Press
14. Mc' Oswel Jamin Sibin (2010). *RFID Based Attendance System*. University of Technology Malaysia: Degree Thesis.
15. Mary Catherine O'Connor (2008). RFID Is Key to Car Clubs' Success. *RFID Journal*. Retrieved 2011.

INTERNET REFERENCES

16. Mexico's Electronic Vehicle Registration system opens with Sirit open road toll technology, <http://www.tollroadsnews.com/node/4513> Dec 29, 2009.
17. Bermuda's RFID Vehicle Registration System Could Save \$2 Million/Year <http://www.rfidjournal.com/article/view/3321>
18. SEEED RFID Reader Manual, www.seeedstudio.com
19. Smart License May Cut Car Theft <http://www.rfidjournal.com/article/view/89>
20. www.wikipedia.org
21. www.rfidnews.com
22. www.globeessolutions.com